

JH40 Jackhammer Exploded Diagram

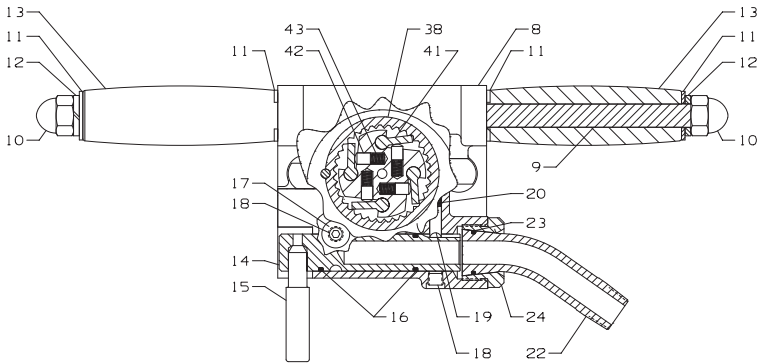
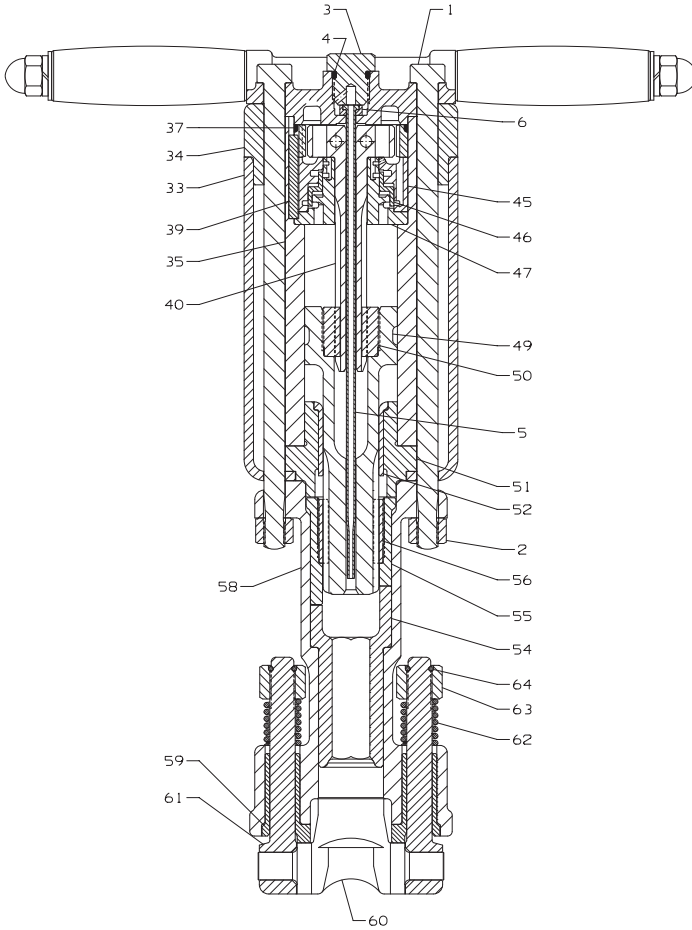

(Dwg. 80160294)

## JH40 Jackhammer Parts List

Item	Part Description	Part Number	Item	Part Description	Part Number
1	Rod, Assembly (2)	50003185	* 49	Piston	50965987
2	Nut, Assembly Rod (2)	50003193	50	Nut, Rifle	50004183
3	Retainer, Tube	50503606		Piston Stem Bearing Assembly	50719772
* 4	O-Ring, Tube Retainer	95086526	51	Bearing, Piston Stem	50719806
5	Tube	50763762	52	Sleeve, Piston Stem Bearing	92046598
* 6	Rubber, Tube	50045673	54	Chuck	
8	Handle	50924380		for JH40C1 (7/8"x3-1/4")	50014554
9	Stud, Handle	50899467		for JH40C2 (7/8"x4-1/4")	50014588
10	Nut, Crown (2)	52134608		for JH40C3 (1"x4-1/4")	50014562
11	Washer (4)	51948016	55	Driver, Chuck	50003375
12	Lock Washer, Handle Bolt (2)	95210415	56	Nut Chuck	50023126
13	Grip Handle (2)	51716454	58	Fronthead	
	Assembly, Throttle Valve	50809748		for JH40C1	50896380
14	Valve, Throttle	50809730		for JH40C2 and JH40C3	50793264
15	Lever, Throttle Valve	51085637	59	Bushing, Fronthead (2)	50009182
* 16	O-Ring, Throttle Valve (2)	95018099	60	Holder, Steel	
17	Pin, Locating	95957668		for JH40C1 and JH40C2	50008945
18	Plug, Handle	95049359		for JH40C3	50008960
19	Plunger, Throttle Valve	50003748	61	Bolt, Steel Holder (2)	50009174
20	Spring, Throttle Valve Plunger	50170927	62	Spring, Steel Holder Bolt (2)	51357606
22	Connection, Hose	50974013	63	Nut, Steel Holder Bolt (2)	50009158
* 23	O-Ring	95086161	64	Retainer Ring,	
24	Cap, Hose Connection	50028117		Steel Holder Bolt Nut (2)	50009190
33	Muffler	50997915	*	Rock Drill Oil	
*	Nameplate	MX90-34		(specially formulated oil for use with percussive construction tools)	
34	Cap, Muffler	50719871			
*	Warning Label	WARNING-6-99	†	Light Oil	
35	Cylinder	50719889		(for use when temperature is 90°F [32°C] or below)	
* 37	Seal, Rotation Ratchet	50719731		1 gallon container	51378701
* 38	Ratchet, Rotation	50719723		5 gallon container	51378727
39	Dowel Pin, Rotation Ratchet	95385720		55 gallon container	51378743
40	Rifle Bar	50003888			
* 41	Pawl, Rotation (4)	50172386	†	Light Oil	
* 42	Plunger, Rotation Pawl (4)	50172394		(for use when temperature is above 90°F [32°C])	
* 43	Spring, Rotation Pawl Plunger (4)	50173269		1 gallon container	51378693
45	Valve, Chest	50719830		5 gallon container	51378719
46	Valve	50006816		55 gallon container	51378735
47	Guide, Valve	50719822			

\* Not Illustrated.

• To keep downtime to a minimum, it is desirable to have on hand certain repair parts. We recommend that you stock one (pair or set) of each part indicated by a (•) for every four tools in service.

† Using any oil other than the oil listed may significantly reduce the life of the tool.

## Parts and Maintenance

When the life of the tool has expired, it is recommended that the tool be disassembled, degreased and parts be separated by material so that they can be recycled.

Tool repair and maintenance should only be carried out by an authorized Service Center.

Refer all communications to the nearest **Ingersoll-Rand** Office or Distributor.

## Related Documentation

For additional information refer to:

Air Percussive Drill Product Safety Information Manual Form 04584975,

Air Percussive Drill Product Information Manual Form 51985323,

Air Percussive Drill Maintenance Information Manual Form 51991057.



www.irtools.com

© 2005 Ingersoll-Rand Company

Form 52086477

Edition 2

March 2005